



Industrial Batteries – Network Power
Marathon M FT
AGM Modular Power.

Specifications

Excellent energy storage system on modular basis.

Specifications







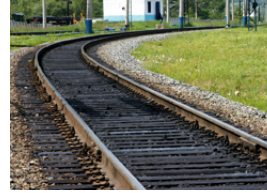

- Marathon FT batteries are excellent AGM power packages offering a simplified modular power concept
- Maintenance-free (no topping up) during the whole service life
- Nominal capacity 35 – 200 Ah
- 12 years design life at 20°C ambient temperature (80% remaining capacity)
- EUROBAT Classification: Long Life
- Designed in accordance with IEC 896-2
- UL 94-V0 version is in compliance with BS 6290 Part 4
- Central degassing
- Grid plate construction consisting of a lead calcium alloy
- Very low gassing due to internal gas recombination (99% efficient)
- Low self discharge rate
- Short recharging time
- Proof against deep discharge according to DIN 43 539 T5
- Trouble-free transportation of operational blocks, no restrictions for most rail, road, sea and air transportation (IATA, DGR clause A 67)
- Completely recyclable



Applications

Marathon FT batteries are reliable front terminal power packages, which combine remarkable high current characteristics and a long service life. Conceived as compact modules, they provide the flexibility for the desired power for a broad variety of profiles. Suitable for modular cabinet and rack installation. For telecommunications, and within both utility and UPS applications, Marathon FT batteries are efficient energy storage solutions, especially during extended back-up times. Furthermore this range also offers great benefits for other security applications where the continuity of power is important.



 Design life in years 12	 Nominal capacity 35 - 200 Ah	 Block battery	 Grid plate
 Recyclable	 Valve regulated lead-acid batteries	 Proof against deep discharge	 Maintenance-free (no topping-up)

Exide type designation	Part number	Nom. Voltage V	Nominal capacity C ₁₀ 1.80 Vpc 20 °C Ah	Nominal capacity C ₈ 1.75 Vpc 25 °C Ah	Nominal capacity C ₃ 1.70 Vpc 20 °C Ah	Nominal capacity C ₁ 1.60 Vpc 20 °C Ah	Length l max. mm	Width b/w max. mm	Height h max. mm	Weight approx. kg	Internal resistance acc. IEC60896-21 mOhm	Terminal
M12V35FT	NAMF120035HMOMA	12	35.0	35.0	30.8	27.2	280	107	189	14.0	11.1	M-M6-90
M12V50FT	NAMF120050HMOMA	12	47.0	48.0	41.1	35.2	280	107	231	18.0	9.00	M-M6-90
M12V60FT	NAMF120060HMOMA	12	59.0	59.0	50.2	41.3	280	107	263	23.0	7.90	M-M6-90
M12V90FT	NAMF120090HM0FA	12	86.0	86.0	75.2	65.3	395	105	270	31.0	5.90	F-M6-90
M12V105FT	NAMF120105HM0FA	12	100	104	86.6	71.3	511	110	238	35.8	5.70	F-M6-90
M12V125FT	NAMF120125HM0FA	12	121	125	112	89.4	559	124	283	47.6	4.60	F-M6-90
M12V155FT	NAMF120155HM0FA	12	150	155	131	104	559	124	283	53.8	4.10	F-M6-90
M6V200 FT	NAMT060200HM0FA	6	200	200	167	140	361	131	250	34.0	2.00	F-M6

Installed length of type M06V200FT: 376 mm

Discharge figures are also valid for UL 94-V0 version.

Change "H" to "V" or "A" in the part number.

E.g:

Standard NAMF120035 **H** M0MA

UL 94-V0 NAMF120035 **V** M0MA

Type M6V200FT:

UL 94-V0 NAMT060200 **A** M0FA

Container, terminal and torque

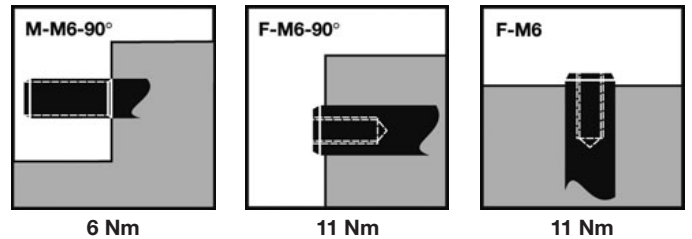

Container: UL 94-HB = Polypropylene (PP)
UL 94-V0 = Polypropylene (PP)

M12V35FT

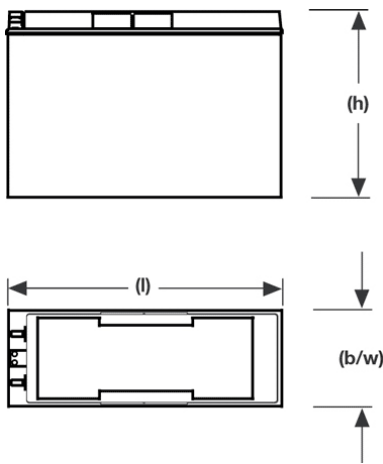

M12V50FT

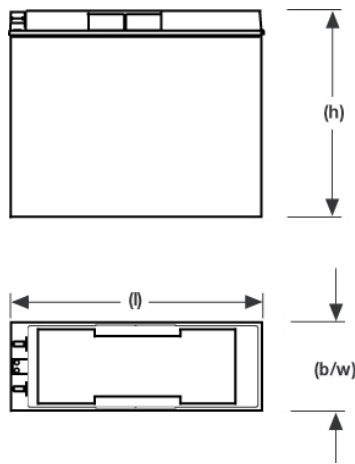

M12V60FT

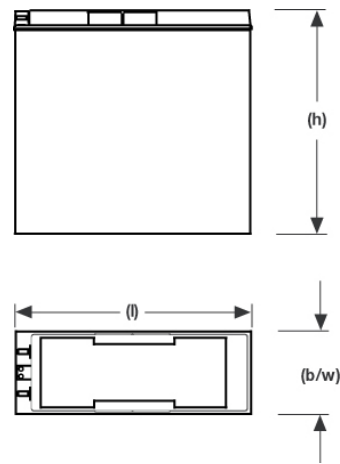

M12V90FT

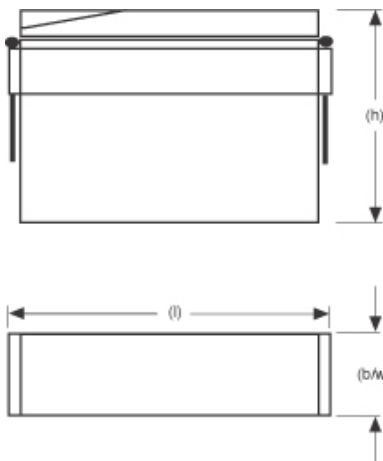

M12V105FT

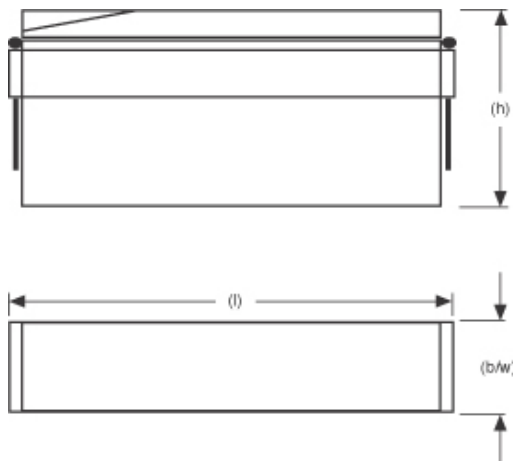

M12V125FT -
M12V155FT

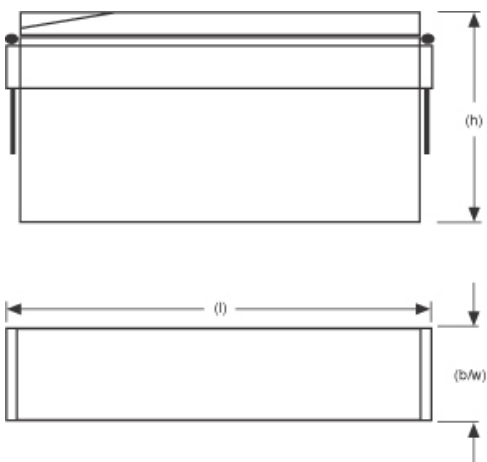

M6V200 FT

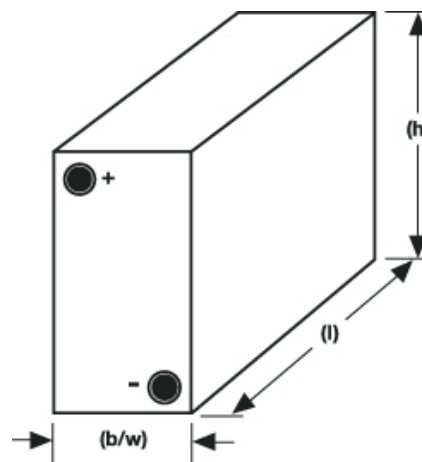

1.94 Vpc - Discharge in A at 20 °C											
Exide type designation	Part number	15 min	30 min	1 h	2 h	3 h	4 h	5 h	8 h	10 h	20 h
M12V35FT	NAMF120035HMOMA	45.6	32.2	19.9	11.0	7.70	6.00	5.00	3.30	2.70	1.50
M12V50FT	NAMF120050HMOMA	67.4	43.7	26.1	14.8	10.5	8.20	6.70	4.40	3.60	1.90
M12V60FT	NAMF120060HMOMA	73.0	49.7	30.6	17.6	12.7	10.1	8.50	5.60	4.60	2.50
M12V90FT	NAMF120090HM0FA	106	76.0	47.1	26.8	19.5	15.5	12.7	8.40	6.90	3.70
M12V105FT	NAMF120105HM0FA	121	79.9	52.4	30.6	22.4	17.9	14.9	9.70	8.00	4.20
M12V125FT	NAMF120125HM0FA	97.5	77.9	62.2	36.7	27.0	21.2	17.4	11.5	9.50	5.00
M12V155FT	NAMF120155HM0FA	122	95.1	74.0	46.3	33.5	26.4	21.9	14.4	11.8	6.30
M6V200FT	NAMT060200AM0FA	131	131	90.7	55.0	40.4	32.4	27.4	18.8	15.4	8.30
1.92 Vpc - Discharge in A at 20 °C											
Exide type designation	Part number	15 min	30 min	1 h	2 h	3 h	4 h	5 h	8 h	10 h	20 h
M12V35FT	NAMF120035HMOMA	50.2	34.4	21.4	11.8	8.30	6.40	5.30	3.50	2.90	1.60
M12V50FT	NAMF120050HMOMA	73.0	46.8	28.0	16.0	11.2	8.70	7.10	4.70	3.80	2.10
M12V60FT	NAMF120060HMOMA	79.2	53.7	33.1	18.9	13.6	10.8	9.10	6.00	4.90	2.60
M12V90FT	NAMF120090HM0FA	120	81.2	50.5	28.6	20.5	16.2	13.5	8.90	7.30	3.90
M12V105FT	NAMF120105HM0FA	132	86.0	55.9	32.4	23.5	18.8	15.8	10.3	8.40	4.50
M12V125FT	NAMF120125HM0FA	125	91.7	67.3	39.7	29.2	22.7	18.6	12.2	10.1	5.40
M12V155FT	NAMF120155HM0FA	149	108	78.8	49.1	35.1	27.7	23.0	15.4	12.5	6.60
M6V200FT	NAMT060200AM0FA	159	155	97.8	59.0	43.1	34.5	29.0	20.0	16.4	8.80
1.90 Vpc - Discharge in A at 20 °C											
Exide type designation	Part number	15 min	30 min	1 h	2 h	3 h	4 h	5 h	8 h	10 h	20 h
M12V35FT	NAMF120035HMOMA	56.4	36.8	22.9	12.5	8.80	6.80	5.60	3.70	3.10	1.70
M12V50FT	NAMF120050HMOMA	79.2	50.2	29.6	17.0	11.9	9.20	7.50	4.90	4.00	2.20
M12V60FT	NAMF120060HMOMA	86.6	58.0	35.7	20.2	14.5	11.5	9.60	6.40	5.20	2.80
M12V90FT	NAMF120090HM0FA	130	86.7	54.0	30.3	21.7	17.2	14.2	9.30	7.70	4.10
M12V105FT	NAMF120105HM0FA	141	91.7	59.4	34.1	24.7	19.6	16.4	10.9	8.90	4.70
M12V125FT	NAMF120125HM0FA	152	105	72.6	42.4	31.1	24.0	19.7	12.9	10.6	5.70
M12V155FT	NAMF120155HM0FA	177	122	83.9	52.0	37.0	29.1	24.2	16.4	13.3	7.00
M6V200FT	NAMT060200AM0FA	188	166	105	63.1	45.8	36.6	30.7	21.1	17.3	9.30
1.87 Vpc - Discharge in A at 20 °C											
Exide type designation	Part number	15 min	30 min	1 h	2 h	3 h	4 h	5 h	8 h	10 h	20 h
M12V35FT	NAMF120035HMOMA	61.3	39.3	24.4	13.3	9.30	7.20	5.90	3.90	3.20	1.70
M12V50FT	NAMF120050HMOMA	85.7	53.8	31.2	17.6	12.5	9.70	7.90	5.20	4.30	2.30
M12V60FT	NAMF120060HMOMA	93.3	60.9	37.4	21.2	15.2	12.0	10.0	6.70	5.50	2.90
M12V90FT	NAMF120090HM0FA	142	93.2	57.4	32.1	23.2	18.0	14.8	9.80	8.00	4.40
M12V105FT	NAMF120105HM0FA	153	97.9	62.6	35.8	25.8	20.5	17.1	11.5	9.30	4.90
M12V125FT	NAMF120125HM0FA	169	115	78.0	45.0	33.0	25.5	20.9	13.7	11.2	6.10
M12V155FT	NAMF120155HM0FA	196	136	89.5	54.9	39.0	30.6	25.4	17.1	13.9	7.30
M6V200FT	NAMT060200AM0FA	231	182	115	67.0	48.6	38.7	32.5	22.4	18.3	9.80
1.85 Vpc - Discharge in A at 20 °C											
Exide type designation	Part number	15 min	30 min	1 h	2 h	3 h	4 h	5 h	8 h	10 h	20 h
M12V35FT	NAMF120035HMOMA	64.8	41.0	25.4	13.8	9.60	7.50	6.10	4.00	3.30	1.80
M12V50FT	NAMF120050HMOMA	90.2	56.3	32.2	18.3	13.0	10.0	8.20	5.40	4.40	2.40
M12V60FT	NAMF120060HMOMA	98.4	63.0	38.6	21.9	15.7	12.4	10.3	6.90	5.60	3.00
M12V90FT	NAMF120090HM0FA	152	97.9	59.5	33.2	23.6	18.4	15.1	10.1	8.30	4.50
M12V105FT	NAMF120105HM0FA	155	102	64.7	36.9	26.6	21.0	17.6	11.8	9.60	5.20
M12V125FT	NAMF120125HM0FA	175	119	79.2	46.5	34.3	26.5	21.6	14.1	11.6	6.30
M12V155FT	NAMF120155HM0FA	220	150	92.9	56.9	40.4	31.6	26.2	17.6	14.3	7.60
M6V200FT	NAMT060200AM0FA	259	191	122	70.1	50.6	40.2	33.6	23.0	18.9	10.1

1.83 Vpc - Discharge in A at 20 °C											
Exide type designation	Part number	15 min	30 min	1 h	2 h	3 h	4 h	5 h	8 h	10 h	20 h
M12V35FT	NAMF120035HMOMA	66.9	41.9	25.8	14.0	9.80	7.60	6.20	4.10	3.40	1.80
M12V50FT	NAMF120050HMOMA	93.0	57.9	32.7	18.4	13.1	10.3	8.40	5.50	4.50	2.40
M12V60FT	NAMF120060HMOMA	101	65.0	39.3	22.3	16.0	12.6	10.5	7.00	5.70	3.00
M12V90FT	NAMF120090HMOMA	159	100	61.0	34.0	24.0	18.7	15.4	10.2	8.40	4.60
M12V105FT	NAMF120105HMOMA	163	104	66.4	37.8	27.2	21.5	17.9	12.0	9.80	5.20
M12V125FT	NAMF120125HMOMA	186	124	81.8	47.7	35.2	27.1	22.2	14.5	11.8	6.30
M12V155FT	NAMF120155HMOMA	233	157	95.9	58.1	41.3	32.3	26.8	18.0	14.6	7.70
M6V200FT	NAMT060200AMOMA	276	199	126	71.9	51.8	41.0	34.2	23.4	19.3	10.2
1.80 Vpc - Discharge in A at 20 °C											
Exide type designation	Part number	15 min	30 min	1 h	2 h	3 h	4 h	5 h	8 h	10 h	20 h
M12V35FT	NAMF120035HMOMA	70.3	43.3	26.3	14.3	10.0	7.80	6.40	4.20	3.50	1.90
M12V50FT	NAMF120050HMOMA	97.3	60.1	33.5	18.7	13.3	10.1	8.60	5.70	4.70	2.40
M12V60FT	NAMF120060HMOMA	106	67.4	39.6	22.6	16.3	12.9	10.8	7.20	5.90	3.10
M12V90FT	NAMF120090HMOMA	170	105	63.0	35.0	24.6	19.1	15.7	10.4	8.60	4.70
M12V105FT	NAMF120105HMOMA	179	109	68.3	38.8	27.8	22.0	18.3	12.3	10.0	5.30
M12V125FT	NAMF120125HMOMA	204	132	85.1	49.3	36.3	27.9	22.8	14.9	12.1	6.40
M12V155FT	NAMF120155HMOMA	254	167	99.8	59.6	42.3	33.1	27.4	18.4	15.0	7.90
M6V200FT	NAMT060200AMOMA	297	210	132	75.1	53.8	42.5	35.4	24.1	20.0	10.5
1.78 Vpc - Discharge in A at 20 °C											
Exide type designation	Part number	15 min	30 min	1 h	2 h	3 h	4 h	5 h	8 h	10 h	20 h
M12V35FT	NAMF120035HMOMA	71.4	43.6	26.4	14.4	10.1	7.80	6.40	4.20	3.50	1.90
M12V50FT	NAMF120050HMOMA	98.3	60.7	33.8	18.9	13.4	10.5	8.70	5.70	4.70	2.40
M12V60FT	NAMF120060HMOMA	107	67.9	39.7	22.7	16.4	13.0	10.9	7.30	5.90	3.10
M12V90FT	NAMF120090HMOMA	174	106	63.6	35.2	24.7	19.2	15.8	10.5	8.60	4.70
M12V105FT	NAMF120105HMOMA	184	112	69.3	39.3	28.2	22.3	18.5	12.5	10.1	5.30
M12V125FT	NAMF120125HMOMA	214	136	86.7	49.9	36.8	28.3	23.1	15.1	12.3	6.50
M12V155FT	NAMF120155HMOMA	265	172	101	60.4	42.8	33.6	27.8	18.6	15.2	7.90
M6V200FT	NAMT060200AMOMA	309	216	134	76.3	54.6	43.0	35.8	24.3	20.0	10.6
1.75 Vpc - Discharge in A at 20 °C											
Exide type designation	Part number	15 min	30 min	1 h	2 h	3 h	4 h	5 h	8 h	10 h	20 h
M12V35FT	NAMF120035HMOMA	72.6	44.0	26.5	14.4	10.2	7.90	6.60	4.30	3.50	1.90
M12V50FT	NAMF120050HMOMA	99.3	61.0	34.3	19.1	13.5	10.6	8.80	5.80	4.70	2.50
M12V60FT	NAMF120060HMOMA	109	68.8	40.1	23.0	16.6	13.1	11.0	7.30	6.00	3.20
M12V90FT	NAMF120090HMOMA	178	108	64.0	35.5	24.9	19.4	15.9	10.6	8.70	4.70
M12V105FT	NAMF120105HMOMA	190	115	70.0	39.8	28.5	22.5	18.7	12.7	10.3	5.40
M12V125FT	NAMF120125HMOMA	233	141	88.1	50.5	37.2	28.6	23.4	15.2	12.4	6.50
M12V155FT	NAMF120155HMOMA	275	174	103	60.8	43.2	33.9	28.1	18.9	15.4	8.00
M6V200FT	NAMT060200AMOMA	323	220	135	76.9	55.2	43.6	36.3	24.6	20.2	10.7
1.73 Vpc - Discharge in A at 20 °C											
Exide type designation	Part number	15 min	30 min	1 h	2 h	3 h	4 h	5 h	8 h	10 h	20 h
M12V35FT	NAMF120035HMOMA	73.2	44.4	26.6	14.4	10.2	8.00	6.60	4.30	3.50	1.90
M12V50FT	NAMF120050HMOMA	100	61.3	34.4	19.1	13.6	10.7	8.90	5.80	4.70	2.50
M12V60FT	NAMF120060HMOMA	110	69.0	40.3	23.0	16.6	13.2	11.0	7.40	6.00	3.20
M12V90FT	NAMF120090HMOMA	184	109	64.4	35.6	25.0	19.4	16.0	10.6	8.70	4.70
M12V105FT	NAMF120105HMOMA	192	116	70.6	40.0	28.7	22.6	18.8	12.7	10.3	5.40
M12V125FT	NAMF120125HMOMA	236	143	88.8	50.8	37.3	28.8	23.5	15.3	12.5	6.70
M12V155FT	NAMF120155HMOMA	287	177	104	61.2	43.5	34.1	28.2	19.0	15.4	8.00
M6V200FT	NAMT060200AMOMA	333	223	136	77.4	55.5	43.9	36.5	24.7	20.3	10.7

1.70 Vpc - Discharge in A at 20 °C											
Exide type designation	Part number	15 min	30 min	1 h	2 h	3 h	4 h	5 h	8 h	10 h	20 h
M12V35FT	NAMF120035HMOMA	74.0	44.6	26.7	14.4	10.3	8.10	6.70	4.40	3.60	1.90
M12V50FT	NAMF120050HMOMA	101	61.5	34.6	19.3	13.7	10.7	8.90	5.80	4.70	2.50
M12V60FT	NAMF120060HMOMA	110	69.6	40.5	23.2	16.7	13.3	11.1	7.40	6.00	3.20
M12V90FT	NAMF120090HM0FA	187	110	64.7	35.8	25.1	19.5	16.0	10.6	8.70	4.80
M12V105FT	NAMF120105HM0FA	195	118	71.3	40.4	28.9	22.8	18.9	12.8	10.4	5.40
M12V125FT	NAMF120125HM0FA	241	147	89.7	51.3	37.5	29.0	23.7	15.5	12.6	6.70
M12V155FT	NAMF120155HM0FA	300	179	105	61.7	43.9	34.4	28.4	19.1	15.5	8.00
M6V200FT	NAMT060200AM0FA	343	226	137	77.8	55.8	55.8	36.7	27.9	20.4	10.8
1.67 Vpc - Discharge in A at 20 °C											
Exide type designation	Part number	15 min	30 min	1 h	2 h	3 h	4 h	5 h	8 h	10 h	20 h
M12V35FT	NAMF120035HMOMA	74.9	44.9	26.9	14.5	10.3	8.10	6.70	4.40	3.60	1.90
M12V50FT	NAMF120050HMOMA	102	61.7	34.7	19.3	13.8	10.8	9.00	5.90	4.80	2.50
M12V60FT	NAMF120060HMOMA	111	69.9	40.7	23.3	16.8	13.3	11.1	7.50	6.10	3.20
M12V90FT	NAMF120090HM0FA	191	111	64.9	35.9	25.2	19.6	16.1	10.7	8.80	4.80
M12V105FT	NAMF120105HM0FA	199	120	72.0	40.8	29.1	22.9	19.0	12.9	10.4	5.40
M12V125FT	NAMF120125HM0FA	248	150	90.6	51.7	37.6	29.2	23.9	15.6	12.7	6.80
M12V155FT	NAMF120155HM0FA	307	180	106	62.2	44.2	34.6	28.6	19.2	15.6	8.00
M6V200FT	NAMT060200AM0FA	351	229	138	78.3	56.1	44.3	36.9	25.1	20.5	10.8
1.65 Vpc - Discharge in A at 20 °C											
Exide type designation	Part number	15 min	30 min	1 h	2 h	3 h	4 h	5 h	8 h	10 h	20 h
M12V35FT	NAMF120035HMOMA	75.5	45.0	27.0	14.6	10.3	8.10	6.80	4.40	3.60	1.90
M12V50FT	NAMF120050HMOMA	103	62.0	34.9	19.3	13.8	10.9	9.10	5.90	4.80	2.50
M12V60FT	NAMF120060HMOMA	111	70.5	40.9	23.4	16.9	13.4	11.2	7.50	6.10	3.20
M12V90FT	NAMF120090HM0FA	193	112	65.1	36.0	25.2	19.6	16.1	10.7	8.80	4.80
M12V105FT	NAMF120105HM0FA	200	120	72.7	41.0	29.2	23.0	19.1	12.9	10.5	5.40
M12V125FT	NAMF120125HM0FA	250	152	91.3	52.0	37.7	29.3	24.1	15.7	12.8	6.80
M12V155FT	NAMF120155HM0FA	312	182	106	62.5	44.4	34.7	28.7	19.2	15.6	8.20
M6V200FT	NAMT060200AM0FA	357	231	139	78.7	56.3	44.4	37.0	25.1	20.6	10.8

1.94 Vpc - Discharge in W/block at 20 °C										
Exide type designation	Part number	15 min	30 min	1 h	2 h	3 h	4 h	5 h	8 h	10 h
M12V35FT	NAMF120035HMOMA	564	377	231	130	92.5	72.4	59.8	40.0	33.1
M12V50FT	NAMF120050HMOMA	731	492	311	184	129	100	82.5	54.7	44.9
M12V60FT	NAMF120060HMOMA	882	597	365	211	153	121	102	67.6	55.1
M12V90FT	NAMF120090HMOFA	1184	889	562	324	235	187	156	103	84.5
M12V105FT	NAMF120105HMOFA	1250	968	612	352	255	203	170	112	91.9
M12V125FT	NAMF120125HMOFA	1159	1159	729	427	312	250	210	146	118
M12V155FT	NAMF120155HMOFA	1337	1309	862	530	385	307	257	174	142
M6V200FT	NAMT060200HMOFA	867	804	551	341	246	196	164	112	92.1
1.92 Vpc - Discharge in W/block at 20 °C										
Exide type designation	Part number	15 min	30 min	1 h	2 h	3 h	4 h	5 h	8 h	10 h
M12V35FT	NAMF120035HMOMA	601	399	247	139	98.3	76.8	63.5	42.4	35.0
M12V50FT	NAMF120050HMOMA	798	525	331	196	137	106	87.4	57.7	47.4
M12V60FT	NAMF120060HMOMA	1017	644	392	224	162	128	107	71.9	58.5
M12V90FT	NAMF120090HMOFA	1429	944	596	342	247	196	164	109	89.0
M12V105FT	NAMF120105HMOFA	1526	1025	651	373	269	213	180	118	97.1
M12V125FT	NAMF120125HMOFA	1237	1237	778	453	330	264	222	155	125
M12V155FT	NAMF120155HMOFA	1627	1407	916	556	404	321	269	185	150
M6V200FT	NAMT060200HMOFA	1011	857	585	363	262	207	173	118	96.9
1.90 Vpc - Discharge in W/block at 20 °C										
Exide type designation	Part number	15 min	30 min	1 h	2 h	3 h	4 h	5 h	8 h	10 h
M12V35FT	NAMF120035HMOMA	641	422	262	147	104	81.3	67.1	44.8	37.0
M12V50FT	NAMF120050HMOMA	868	561	351	208	145	112	92.3	60.8	49.9
M12V60FT	NAMF120060HMOMA	1114	694	420	238	171	135	112	76.1	62.0
M12V90FT	NAMF120090HMOFA	1546	1002	630	359	259	205	171	114	93.4
M12V105FT	NAMF120105HMOFA	1642	1085	690	393	283	224	187	125	102
M12V125FT	NAMF120125HMOFA	1321	1321	828	479	348	278	233	164	133
M12V155FT	NAMF120155HMOFA	1916	1517	975	579	419	335	282	195	159
M6V200FT	NAMT060200HMOFA	1153	921	620	386	277	219	183	125	102
1.87 Vpc - Discharge in W/block at 20 °C										
Exide type designation	Part number	15 min	30 min	1 h	2 h	3 h	4 h	5 h	8 h	10 h
M12V35FT	NAMF120035HMOMA	679	444	278	155	109	85.5	70.5	47.0	38.7
M12V50FT	NAMF120050HMOMA	939	596	371	214	152	118	96.8	63.6	52.1
M12V60FT	NAMF120060HMOMA	1130	740	444	251	180	142	118	79.8	65.0
M12V90FT	NAMF120090HMOFA	1665	1061	665	377	271	214	178	120	97.6
M12V105FT	NAMF120105HMOFA	1771	1144	722	410	295	233	194	130	106
M12V125FT	NAMF120125HMOFA	1400	1400	873	504	366	291	244	168	139
M12V155FT	NAMF120155HMOFA	2350	1634	1042	605	440	351	295	203	165
M6V200FT	NAMT060200HMOFA	1340	1006	664	411	294	232	193	131	108
1.85 Vpc - Discharge in W/block at 20 °C										
Exide type designation	Part number	15 min	30 min	1 h	2 h	3 h	4 h	5 h	8 h	10 h
M12V35FT	NAMF120035HMOMA	710	460	288	161	113	88.4	72.8	48.4	39.9
M12V50FT	NAMF120050HMOMA	988	620	387	217	155	122	101	66.0	53.7
M12V60FT	NAMF120060HMOMA	1174	786	449	257	185	147	123	82.3	67.0
M12V90FT	NAMF120090HMOFA	1727	1098	689	389	279	220	183	123	100
M12V105FT	NAMF120105HMOFA	1782	1185	743	422	303	239	200	134	109
M12V125FT	NAMF120125HMOFA	2114	1454	905	521	377	300	251	172	144
M12V155FT	NAMF120155HMOFA	2466	1718	1083	626	454	362	303	209	170
M6V200FT	NAMT060200HMOFA	1475	1067	692	427	305	240	199	134	111

1.83 Vpc - Discharge in W/block at 20 °C										
Exide type designation	Part number	15 min	30 min	1 h	2 h	3 h	4 h	5 h	8 h	10 h
M12V35FT	NAMF120035HMOMA	730	468	293	163	115	89.7	73.9	49.1	40.5
M12V50FT	NAMF120050HMOMA	1014	633	396	221	157	123	102	67.3	54.5
M12V60FT	NAMF120060HMOMA	1217	804	458	261	188	149	124	83.6	68.0
M12V90FT	NAMF120090HM0FA	1794	1125	700	395	282	223	185	124	101
M12V105FT	NAMF120105HM0FA	1863	1216	760	431	309	244	203	137	112
M12V125FT	NAMF120125HM0FA	2178	1489	924	532	385	306	256	176	148
M12V155FT	NAMF120155HM0FA	2588	1776	1112	641	464	369	309	213	173
M6V200FT	NAMT060200HM0FA	1536	1110	712	437	311	244	203	138	112
1.80 Vpc - Discharge in W/block at 20 °C										
Exide type designation	Part number	15 min	30 min	1 h	2 h	3 h	4 h	5 h	8 h	10 h
M12V35FT	NAMF120035HMOMA	762	481	299	167	117	91.6	75.5	50.2	41.3
M12V50FT	NAMF120050HMOMA	1055	653	407	227	161	126	104	68.8	55.6
M12V60FT	NAMF120060HMOMA	1287	832	472	268	192	152	127	85.6	69.5
M12V90FT	NAMF120090HM0FA	1900	1167	717	403	288	227	188	127	103
M12V105FT	NAMF120105HM0FA	1983	1249	780	441	316	249	207	140	114
M12V125FT	NAMF120125HM0FA	2255	1532	949	545	394	313	262	180	151
M12V155FT	NAMF120155HM0FA	2772	1853	1148	658	476	378	316	218	177
M6V200FT	NAMT060200HM0FA	1649	1182	749	453	322	253	210	142	116
1.78 Vpc - Discharge in W/block at 20 °C										
Exide type designation	Part number	15 min	30 min	1 h	2 h	3 h	4 h	5 h	8 h	10 h
M12V35FT	NAMF120035HMOMA	773	485	301	168	118	92.3	76.0	50.5	41.6
M12V50FT	NAMF120050HMOMA	1059	658	409	228	162	127	105	69.1	55.8
M12V60FT	NAMF120060HMOMA	1315	840	476	270	193	153	127	86.1	69.9
M12V90FT	NAMF120090HM0FA	1940	1183	722	404	290	228	189	128	104
M12V105FT	NAMF120105HM0FA	2037	1272	789	446	319	252	210	142	115
M12V125FT	NAMF120125HM0FA	2291	1552	960	551	398	316	264	181	153
M12V155FT	NAMF120155HM0FA	2874	1892	1166	668	482	382	320	220	179
M6V200FT	NAMT060200HM0FA	1705	1212	760	457	325	255	211	143	117
1.75 Vpc - Discharge in W/block at 20 °C										
Exide type designation	Part number	15 min	30 min	1 h	2 h	3 h	4 h	5 h	8 h	10 h
M12V35FT	NAMF120035HMOMA	790	485	304	170	119	93.2	76.8	51.1	42.1
M12V50FT	NAMF120050HMOMA	1088	668	413	229	163	128	106	69.6	56.1
M12V60FT	NAMF120060HMOMA	1358	852	482	272	195	154	128	86.8	70.5
M12V90FT	NAMF120090HM0FA	1980	1200	728	405	290	229	190	129	105
M12V105FT	NAMF120105HM0FA	2116	1292	796	450	322	254	211	143	117
M12V125FT	NAMF120125HM0FA	2307	1562	966	553	399	319	267	183	155
M12V155FT	NAMF120155HM0FA	3014	1910	1171	673	484	386	322	220	180
M6V200FT	NAMT060200HM0FA	1798	1246	773	462	327	257	213	144	118
1.73 Vpc - Discharge in W/block at 20 °C										
Exide type designation	Part number	15 min	30 min	1 h	2 h	3 h	4 h	5 h	8 h	10 h
M12V35FT	NAMF120035HMOMA	794	487	305	170	120	93.6	77.1	51.2	42.2
M12V50FT	NAMF120050HMOMA	1094	671	413	230	163	128	106	69.8	56.3
M12V60FT	NAMF120060HMOMA	1371	855	483	273	196	154	128	87.0	70.7
M12V90FT	NAMF120090HM0FA	2016	1212	732	405	291	230	191	129	105
M12V105FT	NAMF120105HM0FA	2126	1304	800	451	323	255	212	144	117
M12V125FT	NAMF120125HM0FA	2324	1573	970	554	400	320	267	183	155
M12V155FT	NAMF120155HM0FA	3062	1928	1177	679	488	388	325	221	180
M6V200FT	NAMT060200HM0FA	1839	1281	782	465	329	258	214	145	118

1.70 Vpc - Discharge in W/block at 20 °C										
Exide type designation	Part number	15 min	30 min	1 h	2 h	3 h	4 h	5 h	8 h	10 h
M12V35FT	NAMF120035HMOMA	801	490	308	172	120	94.1	77.5	51.5	42.4
M12V50FT	NAMF120050HMOMA	1104	674	414	231	164	129	106	70.2	56.5
M12V60FT	NAMF120060HMOMA	1391	858	485	274	196	155	129	87.4	70.9
M12V90FT	NAMF120090HMOFA	2038	1221	735	406	292	231	192	129	105
M12V105FT	NAMF120105HMOFA	2143	1312	803	453	324	256	213	144	117
M12V125FT	NAMF120125HMOFA	2340	1582	974	555	400	320	268	185	155
M12V155FT	NAMF120155HMOFA	3137	1945	1183	682	492	390	326	222	180
M6V200FT	NAMT060200HMOFA	1906	1309	790	467	330	259	215	145	118
1.67 Vpc - Discharge in W/block at 20 °C										
Exide type designation	Part number	15 min	30 min	1 h	2 h	3 h	4 h	5 h	8 h	10 h
M12V35FT	NAMF120035HMOMA	808	493	309	173	121	94.7	77.9	51.7	42.6
M12V50FT	NAMF120050HMOMA	1113	678	416	232	165	129	107	70.5	56.7
M12V60FT	NAMF120060HMOMA	1412	862	487	275	197	156	130	87.7	71.2
M12V90FT	NAMF120090HMOFA	2061	1228	737	407	292	231	192	130	105
M12V105FT	NAMF120105HMOFA	2158	1321	807	455	326	257	213	145	118
M12V125FT	NAMF120125HMOFA	2357	1591	978	557	401	320	269	185	156
M12V155FT	NAMF120155HMOFA	3218	1961	1189	686	494	392	327	222	181
M6V200FT	NAMT060200HMOFA	1986	1339	799	469	331	260	215	145	119
1.65 Vpc - Discharge in W/block at 20 °C										
Exide type designation	Part number	15 min	30 min	1 h	2 h	3 h	4 h	5 h	8 h	10 h
M12V35FT	NAMF120035HMOMA	812	495	309	174	122	95.0	78.2	51.9	42.7
M12V50FT	NAMF120050HMOMA	1120	680	416	232	165	129	107	70.7	56.9
M12V60FT	NAMF120060HMOMA	1986	1339	799	469	331	260	215	145	119
M12V90FT	NAMF120090HMOFA	2073	1235	739	408	293	231	193	130	105
M12V105FT	NAMF120105HMOFA	2169	1326	809	456	326	257	214	145	118
M12V125FT	NAMF120125HMOFA	2373	1600	981	557	403	321	269	186	157
M12V155FT	NAMF120155HMOFA	3267	1977	1196	688	496	393	328	223	182
M6V200FT	NAMT060200HMOFA	2037	1354	805	471	332	260	216	146	119

Exide Technologies Industrial Energy – The Industry Leader.



Exide Technologies is the global leader in stored electrical energy solutions with subsidiaries in more than 80 countries. Based on over 100 years of experience in technological innovation, we are partners of OEM and serve the spare parts market for industrial and transportation applications.

Our Global Industrial Energy Business Unit offers an extensive range of storage products and services, including solutions for telecommunications systems, railway applications, mining,

photovoltaic (solar energy), uninterruptible power supply (UPS), electrical power generation and distribution, fork lifts and electric vehicles.

Exide Technologies takes pride in its commitment to a better environment. Its Total Battery Management programme, (an integrated approach to manufacturing, distributing and recycling of lead acid batteries), has been developed to ensure a safe and responsible life cycle for all of its products.

NXMMFTEPDPF01208 Subject to alterations. Dynamic brochures by 5TC ProPublisher.